

Vink UK Limited
t/a Plastestrip
1 - 4 Enterprise Park
St Austell
Cornwall PL25 4EJ

Tel: +44 (0) 172674771 Fax: +44 (0) 172669238
e-mail: sales@plastestrip.com
website: www.plastestrip.com



Agrément Certificate

18/5553

Product Sheet 1

FASTFRAME RAINSCREEN CLADDING SYSTEMS

PLASTESTRIP FASTFRAME RAINSCREEN CLADDING SUPPORT SYSTEM

This Agrément Certificate Product Sheet⁽¹⁾ relates to the Plastestrip FastFrame Rainscreen Cladding Support System, for use as a sub-frame to support cladding on the external or internal wall of new or existing buildings.

(1) Hereinafter referred to as 'Certificate'.

CERTIFICATION INCLUDES:

- factors relating to compliance with Building Regulations where applicable
- factors relating to additional non-regulatory information where applicable
- independently verified technical specification
- assessment criteria and technical investigations
- design considerations
- installation guidance
- regular surveillance of production
- formal three-yearly review.

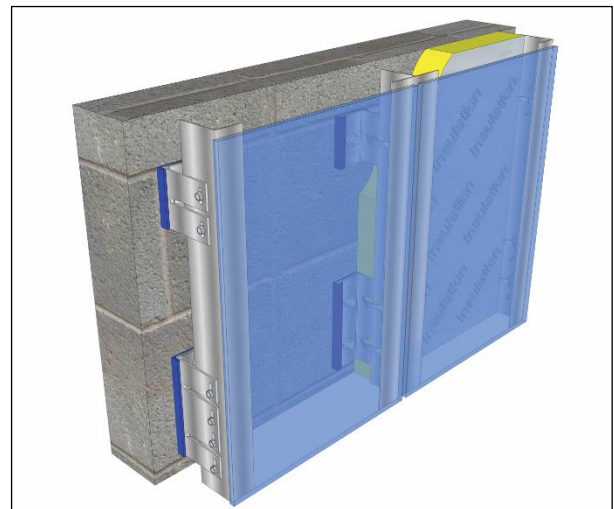

KEY FACTORS ASSESSED

Mechanical resistance and stability — the system can be designed to support the cladding and to transfer the design loads to the substrate wall structure (see section 6).

Behaviour in relation to fire — the system has an A1 reaction to fire classification in accordance with the national Building Regulations (see section 7).

Drainage and ventilation — providing correct details are adopted, the system can provide adequate drainage and ventilation behind the cladding (see section 8).

Durability — the support system will have a service life in excess of 35 years (see section 10).



The BBA has awarded this Certificate to the company named above for the system described herein. This system has been assessed by the BBA as being fit for its intended use provided it is installed, used and maintained as set out in this Certificate.

On behalf of the British Board of Agrément

Paul Valentine
Technical Excellence Director

Claire Curtis-Thomas
Chief Executive

Certificate amended on 14 January 2019 to include Regulation 7(2) for England and associated text.

The BBA is a UKAS accredited certification body – Number 113.

The schedule of the current scope of accreditation for product certification is available in pdf format via the UKAS link on the BBA website at www.bbacerts.co.uk

Readers are advised to check the validity and latest issue number of this Agrément Certificate by either referring to the BBA website or contacting the BBA direct.

Any photographs are for illustrative purposes only, do not constitute advice and should not be relied upon.

British Board of Agrément

Bucknalls Lane
Watford
Herts WD25 9BA

©2018

Page 1 of 11

tel: 01923 665300
clientservices@bbacerts.co.uk
www.bbacerts.co.uk

Regulations

In the opinion of the BBA, the Plastestrip FastFrame Rainscreen Cladding Support System, if installed, used and maintained in accordance with this Certificate, can satisfy or contribute to satisfying the relevant requirements of the following Building Regulations (the presence of a UK map indicates that the subject is related to the Building Regulations in the region or regions of the UK depicted):



The Building Regulations 2010 (England and Wales) (as amended)

Requirement:	A1	Loading
Comment:		The system can be designed to adequately transfer the design loads from the cladding to the substrate wall structure. See section 6 of this Certificate.
Requirement:	B4(1)	External fire spread
Comment:		The system is unrestricted by this Requirement. See sections 7.1 to 7.3 of this Certificate.
Regulation:	7	Materials and workmanship (<i>Applicable in Wales only</i>)
Regulation:		Materials and workmanship (<i>Applicable in England only</i>)
Comment:		The system is acceptable. See section 10 and the <i>Installation</i> part of this Certificate.
Regulation:		Materials and workmanship (<i>Applicable in England only</i>)
Comment:		The system is unrestricted by this Regulation. See section 7.2 of this Certificate.



The Building (Scotland) Regulations 2004 (as amended)

Regulation:	8(1)(2)	Durability, workmanship and fitness of materials
Comment:		The system is acceptable. See sections 9 and 10 and the <i>Installation</i> part of this Certificate.
Regulation:	9	Building standards applicable to construction
Standard:	1.1(a)(b)	Structure
Comment:		The system can be designed to adequately transfer the design loads from the cladding to the substrate wall structure, with reference to clause 1.1.1 ⁽¹⁾⁽²⁾ . See section 6 of this Certificate.
Standard:	2.6	Spread to neighbouring buildings
Comment:		The system will contribute to satisfying this Standard, with reference to clause 2.6.4 ⁽¹⁾⁽²⁾ . See section 7.1 of this Certificate.
Standard:	2.7	Spread on external walls
Comment:		The system will contribute to satisfying this Standard, with reference to clause 2.7.1 ⁽¹⁾⁽²⁾ . See sections 7.1 to 7.3 of this Certificate.
Standard:	7.1(a)(b)	Statement of sustainability
Comment:		The system can contribute to meeting the relevant Requirements of Regulation 9, Standards 1 to 6, and, therefore, will contribute to a construction meeting a bronze level of sustainability as defined in this Standard.

(1) Technical Handbook (Domestic).

(2) Technical Handbook (Non-Domestic).



The Building Regulations (Northern Ireland) 2012 (as amended)

Regulation:	23	Fitness of materials and workmanship
Comment:		The system is acceptable. See section 10 and the <i>Installation</i> part of this Certificate.
Regulation:	30	Stability
Comment:		The system can be designed to adequately transfer the design loads from the cladding to the substrate wall structure. See section 6 of this Certificate.

Regulation:	36(a)	External fire spread
Comment:	The system is unrestricted by this Regulation. See sections 7.1 to 7.3 of this Certificate.	

Construction (Design and Management) Regulations 2015 Construction (Design and Management) Regulations (Northern Ireland) 2016

Information in this Certificate may assist the client, designer (including Principal Designer) and contractor (including Principal Contractor) to address their obligations under these Regulations.

See section: *3 Delivery and site handling (3.2, 3.3 and 3.5)* of this Certificate.

Additional Information

NHBC Standards 2018

In the opinion of the BBA, the Plastestrip FastFrame Rainscreen Cladding Support System, if installed, used and maintained in accordance with this Certificate, can satisfy or contribute to satisfying the relevant requirements in relation to *NHBC Standards, Part 6 Superstructure (excluding roofs), Chapter 6.9 Curtain walling and cladding, Clauses 6.9.4 Loads and 6.9.5 Support and fixings.*

Technical Specification

1 Description

1.1 The Plastestrip FastFrame Rainscreen Cladding Support System consists of (see Figure 1):

- FastFrame and ThermaFrame Brackets — L shaped aluminium (FastFrame) and stainless-steel (ThermaFrame) brackets, with a 3 mm rigid PVC thermal isolator pad (outside of the scope of this Certificate) fitted to the back. Two variants of the brackets are available: single and double. The single brackets have a height of 75 mm and the double brackets 150 mm
- L and T Rails — aluminium rails of 'L' and 'T' profiles, fixed to the aluminium or stainless-steel brackets using self-drilling screws (see section 1.3).

Figure 1 Typical rail/bracket arrangement

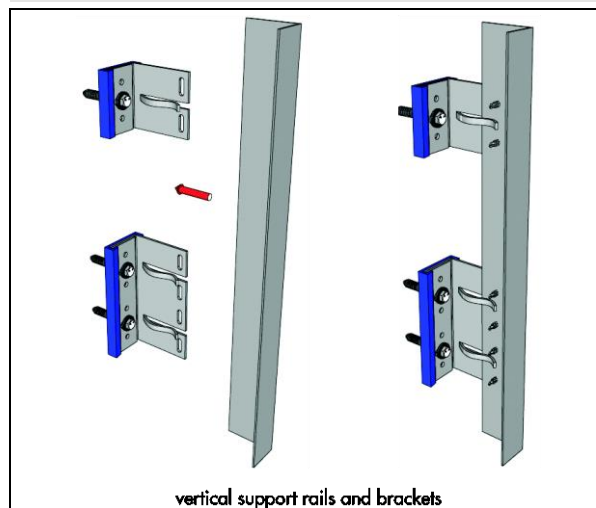

1.2 The system components (see Figure 2) are manufactured with the following characteristics:

- L shaped Aluminium Bracket to Grade 5251-H22 to BS EN 573-3 : 2009
- L shaped Stainless-Steel Bracket to Grade 304 (A2) to BS EN 10088-1 : 2005
- L and T shaped FastFrame Aluminium Rails to Grade EN AW – 6063T6 to BS EN 573-3 : 2009
- L and T shaped FastFrame Aluminium Rails to Grade 6005A T6 to BS EN 573-3 : 2009
- L and T shaped FastFrame Aluminium Rails to Grade 6082 T6 to BS EN 573-3 : 2009
- Brackets: JT4-4, 4.8 x 19 mm, 304 stainless steel (A2) to EN 10088-1 : 2005.

Figure 2 Component details

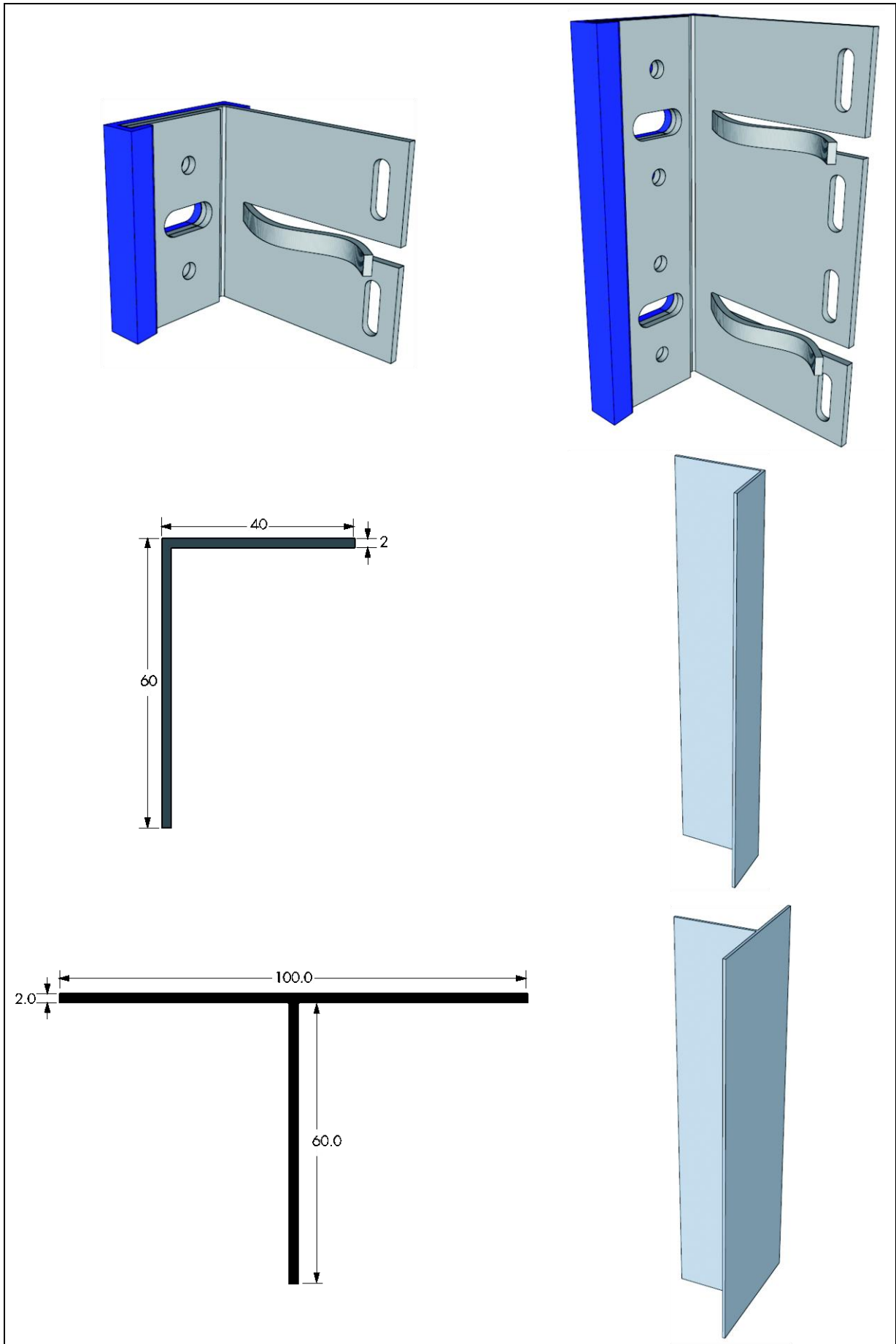

1.3 The rails are fixed to the brackets using Ejot Self-Drill Screws JT4-4-4.8 x 19, see Figure 3.

Figure 3 Self-drilling screws — rail to bracket

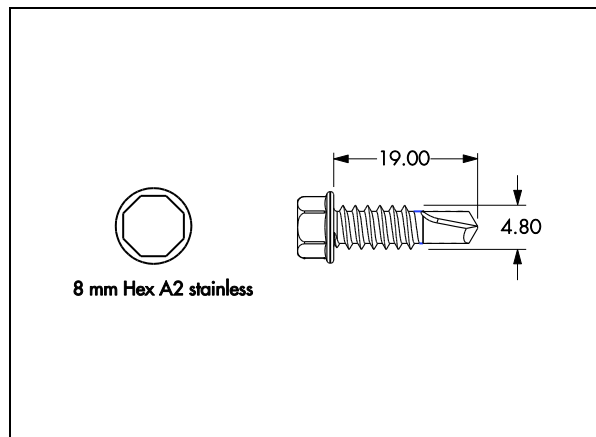

1.4 An ancillary item specified for use with the system and recommended by the Certificate holder, but outside the scope of this Certificate, is FastFrame Isolation 3 mm Rigid PVC Clip.

1.5 Ancillary items outside the scope of this Certificate are fixings between the brackets and the substrate wall.

2 Manufacture

As part of the assessment and ongoing surveillance of product quality, the BBA has:

- agreed with the manufacturer the quality control procedures and product testing to be undertaken
- assessed and agreed the quality control operated over batches of incoming materials
- monitored the production process and verified that it is in accordance with the documented process
- evaluated the process for management of nonconformities
- checked that equipment has been properly tested and calibrated
- undertaken to carry out the above measures on a regular basis through a surveillance process, to verify that the specifications and quality control operated by the manufacturer are being maintained.

3 Delivery and site handling

3.1 The rails carry a label bearing the manufacturer's name and a label bearing the BBA logo incorporating the number of this Certificate.

3.2 Packs of rails should be stacked horizontally, on sufficient bearers to prevent distortion, to a maximum height of one metre. Other components should be stored safely until ready for use.

3.3 The bundles should be stored on a dry, flat and level surface, suitably protected from the weather. Ancillary items should be stored in separate boxes.

3.4 The brackets are delivered to site in cartons of a size suitable for manual handling.

3.5 The system components should be handled with care. Damaged items should be discarded.

3.6 Protective clothing should be worn, as required, and all Health and Safety regulations observed. Care should be exercised when handling long lengths of rail, especially at a height.

Assessment and Technical Investigations

The following is a summary of the assessment and technical investigations carried out on the Plastestrip FastFrame Rainscreen Cladding Support System.

4 Use

4.1 The Plastestrip FastFrame Rainscreen Cladding Support System, when installed in accordance with this Certificate, is satisfactory for use in back ventilated and drained cavity rainscreen cladding systems, as well as for internal cladding, as a sub-frame to support cladding on the external or internal walls of new and existing buildings.

4.2 The substrate wall to which the system is to be fixed must be structurally sound and free of defects, watertight and satisfy the requirements of the national Building Regulations and Standards with respect to structure, heat and sound transmission.

4.3 It is important for designers to ensure that the rails, brackets and fixings between rails and brackets have adequate structural capacity to support cladding panels. Reference should be made to the design and installation requirements of the cladding panel supplier.

5 Practicability of installation

The system is suitable for installation by cladding contractors approved by the Certificate holder.

6 Mechanical resistance and stability



6.1 The substrate wall to which the system is to be fixed should be designed and constructed in accordance with the requirements of the relevant national Building Regulations and Standards.

6.2 Assessment of structural performance of the cladding support systems for individual buildings must be carried out by a designer or a suitably qualified and experienced individual to ensure that:

- fixing of the support brackets to the supporting wall has adequate tensile, shear and pull-out strength (outside the scope of this Certificate). An appropriate number of site-specific pull-out tests must be conducted on the substrate wall to determine the minimum pull-out resistance to failure of the fixings. The characteristic pull-out resistance should be determined in accordance with the guidance given in EOTA TR055 : 2016, using 50% of the mean value of the five smallest measured values at the ultimate load
- fixing of the support brackets to the supporting wall (outside the scope of this Certificate) has adequate corrosion resistance
- the bearing capacity of the fixings between the brackets and the rails is not exceeded
- the support system and cladding to be supported are compatible
- thermal expansion effects of both the support system and the cladding to be supported are taken into consideration in the design and detailing.

6.3 The supporting wall must be able to resist the gravity load from the self-weight of the cladding, the wind actions and any racking loads, without placing reliance on the rail system. No contribution from the cladding system may be assumed in this respect.

6.4 The wind loads on the wall should be calculated in accordance with BS EN 1991-1-4 : 2005 and its UK National Annex. Due consideration should be given to the high-pressure coefficients applicable to corners of the building as recommended in this Standard. In accordance with BS EN 1990 : 2002 and its UK National Annex, it is recommended that a partial load factor of 1.5 is used to determine the ultimate wind load to be resisted by the system.

6.5 A combination of horizontal and vertical actions must be checked by an appropriately qualified design engineer, in accordance with BS EN 1999-1-1 : 2007 and BS EN 1999-1-3 : 2007 and their UK National Annexes, in conjunction to BS EN 1990 : 2002 and BS EN 1991-1-1: 2002 and their UK National Annexes.

6.6 Details of the brackets, with their design loadbearing capacities, are shown in Figure 2. The design load-carrying capacity of the connections should be greater than that of the bracket as given in Table 1.

Table 1 FastFrame Brackets — single and double

	Length (mm)	Width (mm)	Code	Design resistance (F_{RD}) (kN) ⁽¹⁾				
				Tension	Compression	Shear		
				Stainless-steel		Aluminium		
			TBS	FF/FIX				
FastFrame/ThermaFrame	75	65	BR/65	24.5	18.3	6.9		
Bracket –	75	80	BR/80	24.5	16.1	5.5		
Single	75	100	BR/100	24.5	13.1	4.3		
(see Figure 2a)	75	120	BR/120	24.5	10.5	3.4		
	75	140	BR/140	24.5	8.3	2.7		
	75	160	BR/160	24.5	6.7	2.2		
	75	180	BR/180	24.5	5.5	1.7		
	75	200	BR/200	24.5	4.6	1.4		
	75	220	BR/220	24.5	3.8	1.2		
	75	240	BR/240	24.5	3.2	1		
FastFrame/ThermaFrame	150	65	BRD/65	49.1	36.5	22.6		
Bracket –	150	80	BRD/80	49.1	32.3	21.1		
Double	150	100	BRD/100	49.1	26.3	15		
(see Figure 2b)	150	120	BRD/120	49.1	20.9	10.6		
	150	140	BRD/140	49.1	16.7	7.6		
	150	160	BRD/160	49.1	13.4	5.6		
	150	180	BRD/180	49.1	11	4.3		
	150	200	BRD/200	49.1	9.1	3.4		
	150	220	BRD/220	49.1	7.7	2.8		
	150	240	BRD/240	49.1	6.6	2.3		

(1) These design resistances have been calculated according to Section 6 of EN 1999-1-1:2007. Partial safety factors for ultimate limit states γ_{M1} and γ_{M2} from Table 6.1.

Table 2 L and T Rails

Code	dimension 1 (mm)	dimension 2 (mm)	thickness (mm)	Area (mm ²)	Second Moment of Area			Radius of Gyration		Distance to centre of gravity C (mm)	
					Axis x-x (mm ⁴)	Axis y-y (mm ⁴)	Axis x-y (mm ⁴)	Axis x-x (mm)	Axis y-y (mm)		
L Rail section (see Figure 2)	FIX/A NG/H D/40/ 60	40	60	2	196	27797.6	75157.6	24489.8	11.9	19.6	8.8
T Rail section (see Figure 2)	FIX/T EE/H D/100 /60	100	60	2	316	342981.3	36065.3		32.9	10.7	32.0

Table 3 Rail to Bracket fixings

Fixing Code	Grade	Screw diameter (mm)	Length (mm)	Screw head diameter (mm)	Maximum fastened thickness (mm)	Ultimate Shear Strength (kN)
PCF/44/4.8X19	A2/304	4.8	19	8	9	5.10

6.8 The design of the rails and associated connections must satisfy the requirements of BS EN 1999-1-1 : 2007, using the mechanical properties of the aluminium grade adopted. Mid-span deflections between supports should be limited to span/200 and cantilever deflections limited to span/150 at the end of the cantilever.

6.9 In general, the rails should be fixed near the centre of the rail, fastening the rail to the brackets through the bottom of the clotted holes (fixed point) and allowed to expand towards the ends by fastening the rail to the brackets through the centre of the slotted holes (flexible or sliding point). For standard three metre long rails, a gap of 10 mm between adjacent rails is adequate. For calculation purposes, the coefficient of thermal expansion for aluminium may be taken as $23 \times 10^{-6} \cdot K^{-1}$. Existing movement joints in the supporting structure should be maintained through the rail system.

6.10 The design of the installation must be checked by a suitably qualified designer or other appropriately qualified person.

6.11 Any insulation behind the cladding should be suitably fixed to the supporting wall, and protected, to resist the forces of wind suction. Insulation should be, at least, of semi-rigid type (outside the scope of this Certificate) (eg boards or batts).

Impact loading



6.12 The impact resistance of a cladding system is a function of the support framing arrangement and the cladding panel used. The structural engineer should ensure that the cladding system incorporating the Plastestrip Fastframe Rainscreen Cladding Support System has adequate impact resistance for the support frame arrangement and cladding panels used, for the intended location category as defined in ETAG 034 : 2012, Part 1, Table 4.

7 Behaviour in relation to fire



7.1 The aluminium and stainless-steel brackets, rails, and associated rail-to-bracket fixings are non-combustible and, therefore, are classified as Class A1 in accordance with the national Building Regulations.

7.2 The system is not subject to any restriction on building height or proximity to boundaries.

7.3 The thermal isolator pad component is largely protected by the tiles and the pvc clip if they are always used, their loss in the early stages of a fire would not result in the failure of the support system. It is considered that these ancillary components are present in such relatively small quantities that they are unlikely to significantly affect the overall fire performance of the cladding.

7.4 Designers should refer to the relevant national Building Regulations and guidance for detailed conditions of use, particularly in respect of requirements for substrate fire performance, cavity barriers and combustibility limitations for other materials and components used in the overall wall construction, for example, thermal insulation.

8 Drainage and ventilation

8.1 The support system, when incorporated in back-ventilated and drained cavity rainscreen cladding systems, will not have an adverse effect on the removal of water from the cavity by drainage and ventilation.

8.2 For effective removal of moisture from the cavity, a minimum ventilation area of 5000 mm^2 per linear metre must be provided at the building base point and the roof edge. The ventilation openings should be suitably protected with a ventilation mesh or similar or baffled to prevent the ingress of birds, vermin and rain.

8.3 The ventilation pathway behind the cladding must not be allowed to become blocked, nor the insulation (if installed within the cavity) dislodged where it may be vulnerable to wetting.

9 Maintenance



The system is confined behind the cladding panels and does not require any special maintenance.

10 Durability



The system, when designed and installed as described in this Certificate, has a service life in excess of 35 years in normal UK conditions.

11 Reuse and recyclability

The aluminium and stainless-steel components can be recycled.

Installation

12 General

12.1 The system must be installed in accordance with the manufacturer's recommendations and Installation Guide, and the requirements of this Certificate.

12.2 Installers must be approved by the Certificate holder who can provide technical assistance at the design stage and at the start of the installation.

13 Procedure

13.1 Fill out and return a FastFrame Project Checklist from www.plastestrip.com.

13.2 A project specific framing specification sheet will be issued from Plastestrip Profiles based on the information submitted on the Project Checklist. This will specify the maximum spacings allowable between the brackets and rails.

13.3 The brackets (with the insulating pad) are fixed to the substrate wall using fasteners of appropriate type and size (outside the scope of this Certificate), as specified by the framing specification sheet (see section 6.2).

13.4 The rails are inserted into the brackets and, once lined and levelled, are stitched together using self-drilling stainless steel screws (see section 1.3).

13.5 The rails are normally anchored at mid-span using a fixed point bracket, and allowed to expand at the ends using the floating point brackets.

13.6 The cladding panels (outside of the scope of this Certificate) deemed to be compatible with the support system are appropriately fixed to the vertical rails.

Technical Investigations

14 Investigations

An assessment was made of the system's resistance to wind loading, reaction to fire, durability, the production method and associated quality control procedures.

Bibliography

BRE Report BR 135 : 2013 *Fire performance of external insulation for walls of multistorey buildings*

BS EN 573-3 : 2009 Aluminium and aluminium alloys – Chemical composition and form of wrought products – Chemical composition and form of products

BS EN 1990 : 2002 + A1: 2005 *Eurocode — Basis of structural design*

NA to BS EN 1990 : 2002 + A1 : 2005 UK National Annex to *Eurocode — Basis of structural design*

BS EN 1991-1-1 : 2002 *Eurocode 1 — Actions on structures — General actions — Densities, self-weight, imposed loads for buildings*

NA to BS EN 1991-1-1 : 2002 UK National Annex to *Eurocode 1 — Actions on structures — General actions — Densities, self-weight, imposed loads for buildings*

BS EN 1991-1-4 : 2005 + A1 : 2010 *Eurocode 1 — Actions on structures — General actions — Wind actions*

NA to BS EN 1991-1-4 : 2005 + A1 : 2010 UK National Annex to *Eurocode 1 — Actions on structures — General actions — Wind actions*

BS EN 1999-1-1 : 2007 + A1 : 2009 *Eurocode 9 — Design of aluminium structures — General structural rules*

NA to BS EN 1999-1-1 : 2007 + A1: 2009 UK National Annex to *Eurocode 9 — Design of aluminium structures — General structural rules*

BS EN 1999-1-3 : 2007 + A1: 2011 *Eurocode 9 — Design of aluminium structures — Structures susceptible to fatigue*

NA to BS EN 1999-1-3 : 2007 + A1 : 2011 UK National Annex to *Eurocode 9 — Design of aluminium structures — Structures susceptible to fatigue*

ETAG 034 : 2012, Part 1 *Guideline for European Technical Approval of kits for external wall claddings - Ventilated cladding kits comprising cladding components and associated fixings*

EOTA TR055 : 2016 Design of fasteners based on EAD 330232-00-0601

15 Conditions

15.1 This Certificate:

- relates only to the product/system that is named and described on the front page
- is issued only to the company, firm, organisation or person named on the front page – no other company, firm, organisation or person may hold claim that this Certificate has been issued to them
- is valid only within the UK
- has to be read, considered and used as a whole document – it may be misleading and will be incomplete to be selective
- is copyright of the BBA
- is subject to English Law.

15.2 Publications, documents, specifications, legislation, regulations, standards and the like referenced in this Certificate are those that were current and/or deemed relevant by the BBA at the date of issue or reissue of this Certificate.

15.3 This Certificate will remain valid for an unlimited period provided that the product/system and its manufacture and/or fabrication, including all related and relevant parts and processes thereof:

- are maintained at or above the levels which have been assessed and found to be satisfactory by the BBA
- continue to be checked as and when deemed appropriate by the BBA under arrangements that it will determine
- are reviewed by the BBA as and when it considers appropriate.

15.4 The BBA has used due skill, care and diligence in preparing this Certificate, but no warranty is provided.

15.5 In issuing this Certificate the BBA is not responsible and is excluded from any liability to any company, firm, organisation or person, for any matters arising directly or indirectly from:

- the presence or absence of any patent, intellectual property or similar rights subsisting in the product/system or any other product/system
- the right of the Certificate holder to manufacture, supply, install, maintain or market the product/system
- actual installations of the product/system, including their nature, design, methods, performance, workmanship and maintenance
- any works and constructions in which the product/system is installed, including their nature, design, methods, performance, workmanship and maintenance
- any loss or damage, including personal injury, howsoever caused by the product/system, including its manufacture, supply, installation, use, maintenance and removal
- any claims by the manufacturer relating to CE marking.

15.6 Any information relating to the manufacture, supply, installation, use, maintenance and removal of this product/system which is contained or referred to in this Certificate is the minimum required to be met when the product/system is manufactured, supplied, installed, used, maintained and removed. It does not purport in any way to restate the requirements of the Health and Safety at Work etc. Act 1974, or of any other statutory, common law or other duty which may exist at the date of issue or reissue of this Certificate; nor is conformity with such information to be taken as satisfying the requirements of the 1974 Act or of any statutory, common law or other duty of care.